

Date: 08/07/06
Model #: FCA304848T

3048/48 FRP/PC
ASSEMBLY

COVER FEATURES:

- * STANDARD LOAD RATING: 20,800 POUND WHEEL LOAD ON 10 X 20 PLATE
- * POLYMER CONCRETE CONSTRUCTION
- * WEIGHT = 110 POUNDS (EACH HALF)
- * 4 BOLT DOWN LOCATIONS
- * COLOR = CONCRETE GREY
- * NON-SKID SURFACE

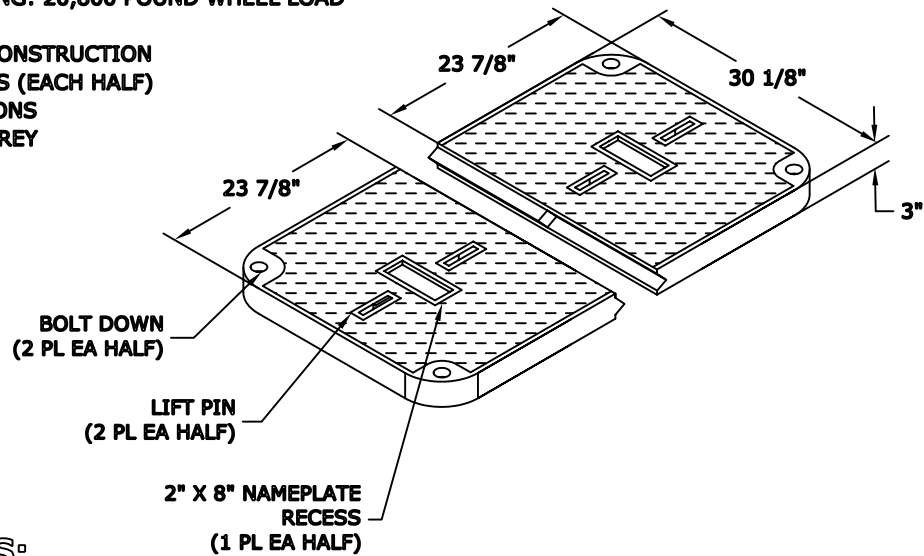

BOX FEATURES:

- * POLYMER CONCRETE RING
- * FIBERGLASS REINFORCED POLYMER CONCRETE BODY
- * BOX WEIGHT W/ RING = 330 POUNDS
- * COLOR OF RING = CONCRETE GREY

